

# batakologi

*by* Tes Tes

---

**Submission date:** 21-Nov-2021 02:07PM (UTC+0700)

**Submission ID:** 1708930242

**File name:** ologi\_Learning\_Model\_Development\_N\_Siregar,\_H\_Sutopo,\_M\_Paat.pdf (617.84K)

**Word count:** 5046

**Character count:** 28163

---

## Mobile Multimedia-based Batakologi Learning Model Development

---

Nurliani Siregar<sup>1,\*</sup>, Hadi Sutopo<sup>2</sup> and Meike Paat<sup>3</sup>

<sup>1</sup>*Nommensen University, Indonesia*

<sup>2</sup>*Kalbis Institute, Indonesia*

<sup>3</sup>*Universitas Negeri Manado, Indonesia* <sup>34</sup> *mail: nurlianisiregar@yahoo.com; hadi.sutopo@kalbis.ac.id; meikepaat@gmail.com*

<sup>\*</sup>*Corresponding Author*

Received 29 April 2019; Accepted 24 April 2020;  
Publication 19 June 2020

### <sup>3</sup> Abstract

The purpose of this study is to develop a mobile multimedia-based Batakologi learning model as the tradition of the Batak culture and lead computer based innovative module products for Junior High School students. The application development method consists of seven phases, namely (1) Research and Preliminary Information Collecting; (2) Planning; (3) Developing Preliminary Product; (4) Preliminary Field Testing; (5) Preliminary Product Revision; (6) Main Field Testing; (7) Operational Product Revision. Data were collected in the research and development using qualitative descriptive analysis of the implementation and results of the design development of the model. Product of this research was the computer based Batakologi learning modules that could be accessed using mobile devices. The findings of the research shows improving student learning atmosphere and it was more fun and independent in learning about Batak culture.

**Keywords:** Learning, batakologi, multimedia, mobile device.

## 1 Introduction

The educational innovation is the first step to increase the professionalism of the teaching or learning systems in education. This research was based on the educational innovation in studying Batak traditional culture. Students have to complete their soft skills and hard skills in order working in the global competition.

Combining the study of educational technology with innovative Batakologi [1] learning system by producing learning modules Batakologi on CD-ROM for junior high school students was the concern of this paper. Graphics and the other multimedia elements provides a tool for presenting scientific information that can be easily displayed and understood [2]. The development Batak culture should be able to observe the condition of student concerned, due to the changes in paradigm of learning which is from teacher-centred learning to student-centred learning [3].

The CD-ROM was used to complete the learning resources about Batakologi that provided as blended learning resources that can be accessed by students everywhere and every time [4]. The boom of information and communication technologies in a wide range of social activities has touched the field of education. Not only CD-ROM has been used to support learning, but several tools can be used to introduce culture and delivering further information that is more interesting and attractive.

### 1.1 Batak culture

Batakologi is part of the curriculum structure contained on the Content Standards in the education unit level curriculum. The Batakologi learning is fitted with local needs in North Sumatera society, Indonesia. Batakologi is curricular activities developing competencies that are fitted to the characteristics and potential of the region, including the area of excellence [1]. The material cannot be grouped into the existing subjects and the substance of Batakologi subjects determined by the education unit, not limited to the subjects of skills. In fact the gap between curriculum Batakologi. The learning itself is motivated by government policy to enact RI Law No. 32 of 2004 concerning Regional Government [5], which calls for the implementation of regional autonomy and the recognition of democracy in the administration of education. Management of education that was initially centralized became decentralized. Decentralization of education management by giving schools the authority to compile the curriculum, concerning the National Education System [6]. Decentralization of education management is the basis for creating a local curriculum that meets the needs of local schools. Local Content

Curriculum is a learning program whose content and media are related to the natural environment, cultural environment, and regional needs, and must be studied by students in the area.

Batakologi learning meets regional needs, is a curricular activity designed to develop competencies tailored to regional specificity and potential, including regional excellence, whose material cannot be grouped into existing themes. The subject matter of Batakologi depends on the subject and is not limited to the subject. Batakologi is part of the curriculum structure of the curriculum included in the curriculum standards of the education unit. In fact, there is a gap between the Batakologi curriculum and the application of Batakologi learning itself. The gap is also caused of the generation between teachers and students. Most of teachers are categorized in X Generation while students are Millennial Generation. How young people learn can be linked to their opportunities and welfare in the future. For this reason, it is important to identify each generation in the way they process the world around them, how they are involved with authority, how this affects families and communities, and what must be done to maximize their chances of achieving their goals. A number of concepts have been put together in an effort to find teaching opportunities in diverse and complex influences in the learning process of 21st century students [7]. Young people tend to use their mobile phone to find news and information than reading books, magazines or another printed media. It influences the characteristics of student in learning, including using media.

## **1.2 Media**

Self-learning method is used to complete regular class learning that students know what is to be learned, how to learn, learning resources that are used, as well as how to collect, sort and processing the information obtained. Autonomy such an asset for students to learn throughout this mind. The characteristics can be nurtured through all groups of the course. Though the learning material is different learning materials for each group of subjects, but the model of teaching and learning methods can be designed giving rise to the independence of the student [8].

## **1.3 Multimedia**

The most common object used in education is multimedia, which is the integration of text, audio, video, graphics and animation into a single medium. Instructional multimedia is the integration of various forms of media in the instructional process [9]. It is the technology that combines print, radio, television, animation, photographs, and illustrations. The integration of many

media will impact to a message. The focus is on instruction and learning. According to the research reports by Mayer and McCarthy 'multimedia has gained acceptance with many benefits derived from its use. The learning gains are greater than 50–56%, consistency of learning is 50–60% better and content retention is 25–50% higher'. The focus of instructional multimedia is the expectation of the learner in doing upon the complexion of the instruction component [10].

When computers and software are used as an integrated application, so that people have new methods of accessing information, these tools can promote and enhance users' understanding of content in powerful ways. They can find information, use images and sound as well as text to communicate what they have learned. The explosive growth of mobile devices is stimulating widespread efforts to clone almost any technology, developed for desktop computers to mobile devices [11]. Mobile technologies offer the opportunity to embed learning in a natural environment. Mobile devices such as smartphones are becoming widely used on schools, and as the shape of computing is evolving more into a mobile environment [12].

#### 1.4 Instructional design for media

Media has become an integral part of education. There are three major forms of multimedia-based instructional application computer-based application, broadcast application, and web-based application [13]. The radio and television as media depends upon the audio and video programmes. Hence, from the software angle, it can be examined that the modular media, though their instructional design will be widely different when it had been integrated inflexible mass media like radio and television or flexible audio and video programmes in designing our multimedia instructional system. To avoid complexity and also to allow space for creativity of the teacher in designing instruction through multimedia, the focus is on instructional design of modular media, namely the audio and video programmes. According to Widyasari et al. [14], mobile based learning can increase student motivation in learning. Her research found that QR code-based learning supported them in learning, since children can be motivated to learn mathematics. The math game as learning resource can be accessed by students anytime and anywhere. While Widjaya and Sutopo said that an interactive multimedia application made learning more enjoyable. Interactive multimedia is multimedia that is provided with an interactivity which is used to carry out to the next process [15].

## 2 Research Method

Some learning development method are used to develop learning such as ADDIE, Kemp, Assure, R&D, etc. [16]. This study uses Research and Development (R&D) according to Borg and Gall that is suitable for this topic [17] which consists of ten following stages as can be seen in Figure 1: (1) Research and Preliminary Information Collecting; (2) Planning; (3) Developing Preliminary Product; (4) Preliminary Field Testing; (5) Preliminary Product Revision; (6) Main Field Testing; (7) Operational Product Revision that produce learning tutorials on CD-ROM and can be used by students to

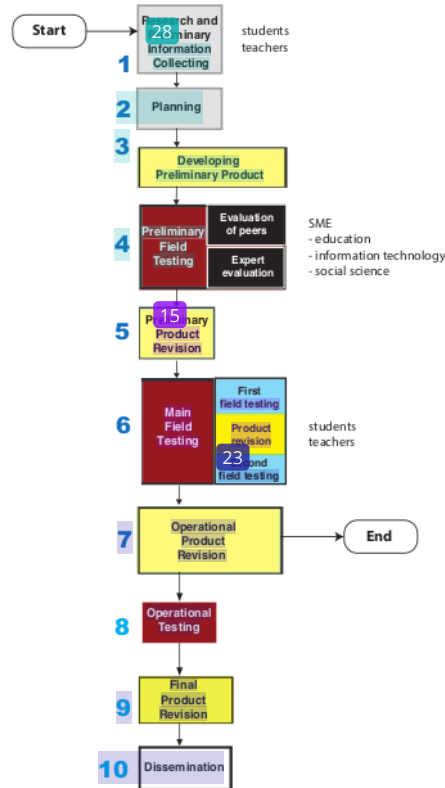

Figure 1 Research and Development [17].

learn puzzle game development; (8) Operational Testing; (9) Final Product Revision; and (10) Dissemination and Implementation.

This research covers only seven phases to meet the needs of the lecture material in the junior high school, include: (1) Research and Preliminary Information Collecting. In this phase, the estimation of identification, learning and research literature on a small scale; (2) Planning. After obtaining the necessary information, the next step is to plan assembling a product; (3) Developing Preliminary Product. After the initiation of the comprehensive plan, the main step in the phase of R&D is to make an early form of learning product that can be tested. At this phase the necessary feedback and suggestions from colleagues in related fields of education, multimedia and social science; (4) Preliminary Field Testing. Expert evaluation conducted after the product completely developed, are related to education, multimedia and social science; (5) Preliminary Product Revision. After the product has been evaluated, the next phase is revising the product; (6) Main Field Testing. After the initial product is revised, conducted field testing for evaluation which using questionnaire to obtain feedback from students and teachers. Interviews are conducted on several students and teachers during the testing phase; and (7) Operational Product Revision. Having conducted main field testing, the next phase is product revision as a learning tutorial mobile phone used by students [18].

### 3 Discussion

#### 3.1 The research and preliminary information collecting

The object of the research was mobile multimedia-based learning about Batak culture, and the research was conducted a junior high school in Medan, Indonesia. Respondents consisted of students and teachers. The data was analysed using the analytical descriptive method and interpreted in a narrative way based on the research findings. The data was analysed based on the research findings of seven phases [14], including research and preliminary information collecting, planning, developing preliminary product, preliminary field testing, preliminary product revision, main field testing. Data that were collected from students and teachers were processed using software for qualitative data process.

The first phase of Research and Development data collection was conducted using open-ended questionnaire and interview in three cities. The

respondents were mostly young people with smartphones gave answers to the questions in Table 1.

As a result of answering the above questions, the majority of respondents gave the following statement as Table 2.

**Table 1** Questionnaires used in the first phase

- 
1. Which one do you prefer using internet and social media or book and other printed media for accessing information?
  2. What kind communication network do you often find information about culture?
  3. What kind of media device do you often use to find new knowledge?
  4. Could the media device be used to deliver learning about culture?
  5. Why do you prefer using mobile phone to find new knowledge.
  6. Mobile phone can be used to access information through Internet depending on the bandwidth. How about it?
  7. Accessing internet need the addition cost. Is it worth for getting the information?
  8. According to your opinion, what kind information about of history and culture is hard to understand?
  9. What kind of media format that is more interesting and easier to be understood?
  10. Do you agree that visualization make people understand history and culture?
- 

**Table 2** Answers of questions in the first phase

- 
1. Most of the respondents liked internet and social media more than book and printed media.
  2. Most respondents found learning about culture from internet.
  3. Most of the respondents used mobile phone for everyday activities, getting information and enhancing their knowledge.
  4. Most of respondents argue that they access many culture information on mobile phone
  5. Most of respondents agree that mobile phone can be used to access information anytime and anywhere.
  6. Almost all respondents explained that the accessing internet using mobile phone is good recently, because the high bandwidth supported them.
  7. Most of the respondents said that the accessing internet cost is worth to gain useful information.
  8. Most of the respondents stated that text-based information about history and culture is hard to understand.
  9. Most of respondents said that animation and video were very interesting and easy to be understood.
  10. Almost all respondents agreed that history and culture would be the most difficult to understand without visualization.
-



### 3.2 Planning

During this phase, organization of learning was created an overall blueprint of how the instruction would be delivered. This process included choosing the optimal methods of instruction and creating useful, action and oriented learning objectives to guide the learning. Potential methods of instruction included classroom learning [1].

Learning organization was made as a master plan of learning that divided into four competencies as follow: (1) **Philosophical life**. Cultural values that reflect the wishes for the good of life, such as longevity, birth, a lot of fun and everything that is good. Honor cultural values for the Batak tribe that reflect a balance in spiritual and material aspects. A cultural value that reflects the sincerity of the Batak people for the sake of justice. The loyalty and sincerity of the Batak people reflects their pledge to promise. A common value to protect the community, that in the social classes of the Batak tribe, guarding is a task that must be performed by the three elements to be the framework that unity the relation of inheritance, wedding, and community. Cultural values among the Batak people that must understand, appreciate, and help each other. Lizards are a symbol of Batak people. It means living Batak people like the life of a lizard. Lizards can live anywhere and have good life skills. As a Batak tribe, a person must adapt to different environment and survive in various problems of life; (2) **Character**. One important that the Batak tribe as one of the tribe who has a hard custom. It means in terms of the style of speech that always uses a loud voice like an angry person, as well as unstoppable speech. The custom is one of the culture of Batak tribe that has been passed down from generation to generation? [19]; (3) **Tradition house**. The traditional Batak house has a rectangular shape. The design is similar to many other traditional houses. The house uses the concept of “Stage House” that can accommodate 5–6 people [20]; and (4) **Singing and dancing**. Singing and dancing are the skills that belong to Batak people. Tor-Tor dance is one type of dance that comes from the Batak tribe on the island of Sumatra. Since about the 13th century. It is very famous to the corners of the world, the evident is many foreign and local tourists who want to learn this dance. Today Tor-Tor dance is turn into an art culture, and a dance that closely related to the spirit world.

The planning phase included creating navigation structure as can be seen in Figure 2 and storyboard to complete the multimedia development [3]. Navigation structure presented the structure of application, while storyboard

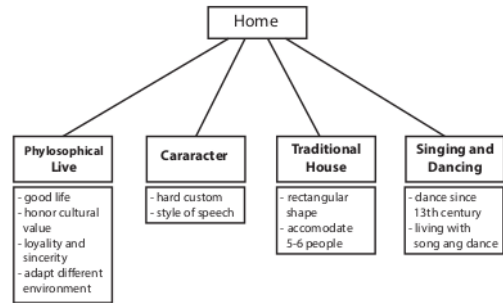

Figure 2 Navigation structure.

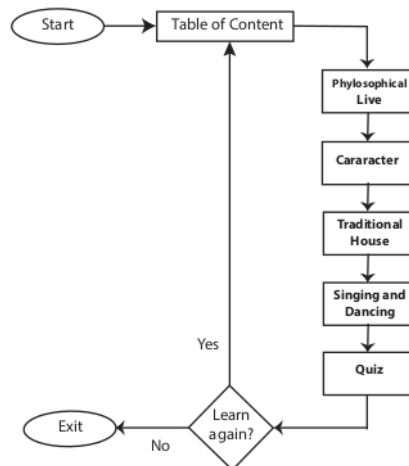
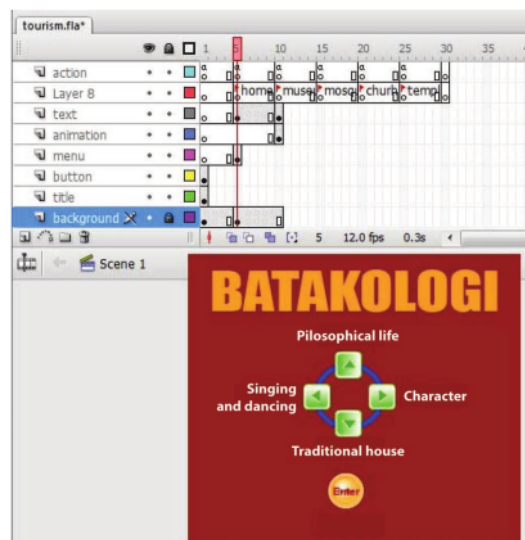

Figure 3 Flowchart of learning design.

presents the detailed view of every scene. The learning is organized as can be seen in Figure 3. The first scene is Table of Content that describe for topics Philosophical life, Character, Traditional house, and Singing and dancing. The next step is accessing the first topics until the fourth one, and doing some quiz to evaluate the learning. Audience can exit the application or access back to the Table of Content.

### 3.3 Developing preliminary product

The multimedia-based learning application was developed to visualize the Batakologi. Developing the multimedia based learning used an authoring tools Adobe Flash to make animation that was provided with object-oriented ActionScript programming [21]. Mobile Multimedia Development for Batakologi learning will give users the first contact point in the graphical user interface component of the mobile application. Users will expose them to frequently used elements such as labels, text boxes, edit boxes, choice sets, and so on. They will also gain proficiency in working with user choices and results, and in processing user input to provide results to users. Users could also view screen navigation so they could learn how to deliver screen information in a mobile application. To create a mobile application using Adobe Flash, several activities must be carried out: (1) Create animated titles and some graphs with color effects, (2) Create buttons with ActionScript that will direct to the certain view (3) Create some stages consist of information about Batak culture using text and images. Figure 4 shows one of the stage designs in Flash document.



**Figure 4** Stage design in Flash document.



**Table 3** Questionnaires used in the first phase

- 
1. Does the learning material organize well in order completing the student competency?
  2. Does the graphic interface meet the principle of graphic design?
  3. Does the flow of information meet the general user requirement?
  4. Can user access the scene his/her need in proper time without an error?
  5. Can the application run on variety of mobile device?
  6. Can the application run on mobile device anywhere?
  7. What is the feature to be improved?
- 

**Table 4** Answers of questions in the first phase

- 
1. The learning material was organized well and complete but it should be enriched with the new subject.
  2. Most of the backgrounds and text looked good. It would be better if the application was provided with light color backgrounds.
  3. The flow of information was good enough.
  4. The user can access the application well. The application could not be accessed using internet network. One of the experts was not sure if it would run on mobile phone using internet well without delay. Audio and image should be synchronized.
  5. Unfortunately the application cannot run on mobile device, neither Android nor iOS platform, unless using Flashfox browser.
  6. The application can be accessed anywhere using internet network, unless the bandwidth is too low. But it is good including the multimedia content access.
  7. The application could be built in the APK format and uploaded to Google Play and AppStore, so audience can download using their mobile phone.
- 

### 3.5 Preliminary product revision

Based on the feedback, criticism and validation by subject matter expert in education, information technology, and social science, individual testing, and testing of small groups, then the product was revised. According to the comment above, the application could not be accessed on Android and Ios platform, unless using Flashfox browser. It was not a problem because many browsers can be used to access the application. eFlashfox, Dolphin and others.

### 3.6 Main field testing

After the product had been revised, the next step was **main field testing** with **the respondents of students** and teachers. At **the end of** the process carried out questionnaires and interviews to complete the data. Results of the answers

to the respondents then analysed to determine whether the questions that created by researchers was worth to the standards. Research findings show that that application was interested for students and it motivated them to study Batakologi by themselves as their local culture. They were proud of their beautiful, hot and friendly culture they have ever had.

33

### **3.7 Operational product revision**

Based on the evaluation of the sixth phase, application was revised in order to meet the need of students and teachers. The revised product would be used in the next phase called Operational Testing in the wide area and respondents.

### **3.8 Discussion**

The format file of Batakologi learning model which has been developed was swf, that can run on computer using Flash Player. Flash Player can be installed on computer, but it cannot be installed on mobile phone. That is why, running on computer laptop was easier than mobile phone. The application can run on mobile device after the activities: (1). Insert the application into web page; and (2) Install Flashfox or Dolphin in the mobile device.

This research was conducted until the Main Field Testing phase, found that the mobile-based learning can improve the environment and student motivation because it is fun and interesting. Moreover, student get their knowledge of local culture that they have never known before. The application can be improved through future research to create the application that can run on Android and Ios without installing a certain browser.

## **4 Conclusion**

According through this paper, the results of the discussion of the Batakologi learning model development can be conclude:

- The development of mobile multimedia based Batakologi learning model that was needed, can improve student learning atmosphere and it was fun and interesting in learning about Batak culture.
- Through Batakologi learning, students increase their proud and love their own culture and were expected to preserve their local culture.
- Batakologi learning model had developed based on research and development needed analysis, planning, design, testing of products with

several revisions and produced the model that can be learned by student individually.

- Some details about Flash technology used in the interactive experiments have been described. The mobile multimedia in its interactive has been well tested by the junior high school students. Adobe Flash, a great authoring tool with ActionScript scripting can be used to develop mobile multimedia application.

## 5 Future Research

For future work, the mobile multimedia needs to be developed as an application that can run on mobile device without using certain browser. The mobile multimedia should be able run on every platform i.e Android and Ios, product and resolution of mobile phone.

## Acknowledgment

Authors would like to thank to Nommensen University, Indonesia that supported this research.

## References

- [1] N. Siregar, "Modul Inovatif Pembelajaran Batakologi dengan Pendekatan Konstruktivistik," *J. Teknol. Pendidik.*, vol. 16, no. 3, pp. 182-197, 2014.
- [2] F. Hill Jr, *Computer Graphics Using Open GL*. Upper Saddle River, NJ: Prentice Hall International, Inc., 2001.
- [3] H. Sutopo, "Multimedia based instructional development: Bubble sort visualization," in *Proceedings of the IEEE International Conference on Software Engineering and Service Sciences, ICSESS*, 2015, vol. 2015-37 November.
- [4] M. Potashnik and J. Capper, "Distance Education: Growth and Diversity." [Online]. Available: <http://www.worldbank.org/fandd/english/pdfs/0398/0110398.pdf>. [Accessed: 14-Aug-2002].
- [5] U. U. RI, "UU RI No.32 tahun 2004 tentang Pemerintahan Daerah Menuntut Pelaksanaan Otonomi Daerah." 2004.
- [6] "UU RI No 20 tahun 2003 tentang Sistem Pendidikan Nasional." 2003.

- [7] H. S. Hoang, T. P. L. Tran, T. T. Nguyen, T. N. Nguyen, and V. A. Hoang, "Street vendor management – Why not?," in *2nd International Conference Software Engineering and Information Management (ICSIM 2019)*, 2019.
- [8] P. B. Sitepu, *Penyusunan Buku Pelajaran*. Jakarta: Verbum, 2006.
- [9] T. Vaughan, *Multimedia Making It Work*. Yogyakarta: Andi Publisher, 2006.
- [10] Mayer and McCarthy, "Instructional Design for Multimedia," 1995. [Online]. Available: <http://cemca.org.in/ckfinder/userfiles/files/Section5.pdf>. [Accessed: 10-Jan-2014].
- [11] Q. H. Mahmoud and A. Dyer, "Integrating BlackBerry Wireless Devices into Computer Programming and Literacy Courses," in *The 45th Annual Southeast Regional Conference (ACM-SE 2007)*, 2007.
- [12] M. K. Chang and S. Law, "Factor structure for Young's Internet Addiction Test: A confirmatory study," *Hum. Behav.*, vol. 24, no. 6, pp. 2597–2619, 2008.
- [13] W. W. Lee and D. L. Owens, *Multimedia-based Instructional Design*. San Francisco, CA: Pfeiffer, 2004.
- [14] W. Widayarsi, H. Sutopo, and M. Agustian, "QR Code-based Learning Development: Accessing Math Game for Children Learning Enhancement," *Int. J. Interact. Mob. Technol.*, vol. 13, no. 11, pp. 111–124, 2019.
- [15] K. Widjaja and H. Sutopo, "Multimedia-Based Global Warming Interactive Application for Elementary School Students," in *ACM International Conference Proceeding Series*, 2017.
- [16] H. Sutopo, "Learning model development of creating a Multimedia Application particularly Puzzle Game," in *Proceedings – 17th IEEE International Conference on Computational Science and Engineering, CSE 2014, Jointly with 13th IEEE International Conference on Ubiquitous Computing and Communications, IUCC 2014, 13th International Symposium on Pervasive Systems*, 2015.
- [17] M. Gall, W. Borg, and J. P. Gall, *Educational Research: An Introduction*, 4th ed. Upper Saddle River, NJ: Pearson, 2003.
- [18] H. Sutopo and W. Pamungkas, "Developing Mathematics Mobile Game to Enhance Learning for Children," in *Proceedings – 2017 IEEE International Conference on Computational Science and Engineering and IEEE/IFIP International Conference on Embedded and Ubiquitous Computing, CSE and EUC 2017*, 2017, vol. 1.



- [19] "Batak culture," 2018. [Online]. Available: <https://steemit.com/culture/@jubelate/batak-culture-sumatra>. [Accessed: 08-Sep-2018].
- [20] "Appreciating the Traditional House of Batak," *Indonesia-tourism*. [Online]. Available: [http://toba.indonesia-tourism.com/batak\\_house.html](http://toba.indonesia-tourism.com/batak_house.html). [Accessed: 12-Nov-2018].
- [21] D. Ypenburg, *Visual Quickstart Guide ActionScript 3.0*. Barkeley, CA: Peachpit Press, 2009.
- [22] B. Chi, "Creating a Flash Lite Game," 2009. [Online]. Available: <http://www.republicofcode.com/%0Atutorials/flash/litegame/5.php>. [Accessed: 10-Sep-2015].

### Biographies



**Nurliani Siregar** is a Lecturer at HKBP Nommensen University who has obtained a master's degree in education (MPd) from Medan State University (2006) and has received a Doctor of Educational Technology from the Jakarta State University (2014). She has received a lecturer certification and also became an educational assessor in the fields of social, philosophy, theology and religion. Entrusted by the University to be the head of the study program and was once a Dean of the Teaching and Education Faculty, University Senate of HKBP Nommensen 2019–2024 period.



**Hadi Sutopo** is researcher of Kalbis Institute, Indonesia. He received his Doctor of Educational Technology from Universitas Negeri Jakarta in 2009, Master of Management Information Systems from Universitas Gunadarma in 1998, and Bachelor of Informatics from Universitas Persada Indonesia YAI in 1995. He has authored many books on multimedia, information technology and educational technology. Many articles on the topics were published in international journals and proceedings. He has reviewed many articles for international journals and conferences covering various emerging topics in information technology especially multimedia. His current research focuses on multimedia, computer graphics, and various aspects of educational technology. Dr. Hadi Sutopo is senior member of Institute of Electrical and Electronics Engineers (IEEE). He is also senior member of International Association of Computer Science and Information Technology (IACSIT) and member of Association for Educational Communications and Technology (AECT). He has served as Conference Chair of many international conferences, chair of technical sessions, and organized many international conferences.



**Meike Paat** was born in Motoling Minahasa/Manado North Sulawesi on May 26, 1962. She received her Bachelor from Department of Biology FPMIPA Manado Manado in 1985, Master of Educational Technology from Jakarta

State IKIP Postgraduate Program and Doctor of Educational Technology from Jakarta State University. She began her career as a biology teacher in several high schools since 1985 as an honorarium worker, and has been a permanent lecturer in the Department of Biology Education Manado State University since 1986. Her researches focus on biology and educational technology.

# batakologi

---

## ORIGINALITY REPORT

---

14%

SIMILARITY INDEX

10%

INTERNET SOURCES

9%

PUBLICATIONS

7%

STUDENT PAPERS

---

## PRIMARY SOURCES

---

1	<a href="https://repository.unj.ac.id">repository.unj.ac.id</a> Internet Source	1%
2	Submitted to Walden University Student Paper	1%
3	<a href="https://journal.unj.ac.id">journal.unj.ac.id</a> Internet Source	1%
4	Submitted to Australian Catholic University Student Paper	1%
5	Zul Anwar, Basuki Wibawa, Nurdin Ibrahim. "DEVELOPMENT OF TEACHING MATERIALS FOR SASAK ALUS LANGUAGE AS CULTURAL PRESERVATION AND LEARNING RESOURCES", Humanities & Social Sciences Reviews, 2019 Publication	1%
6	"Development of Integration Education Model Pela-Gandong Local Based on Local Content in Primary Schools in Ambon City", International Journal of Recent Technology and Engineering, 2019 Publication	1%

---

7	garuda.ristekbrin.go.id Internet Source	<1 %
8	Submitted to Universiti Teknologi MARA Student Paper	<1 %
9	www.eujournal.org Internet Source	<1 %
10	Qusay H. Mahmoud. "Integrating mobile devices into the computer science curriculum", 2008 38th Annual Frontiers in Education Conference, 2008 Publication	<1 %
11	Dewa Gede Hendra Divayana, P. Wayan Arta Suyasa, Ni Ketut Widiartini. "An innovative model as evaluation model for information technology-based learning at ICT vocational schools", Heliyon, 2021 Publication	<1 %
12	Submitted to Universitas PGRI Palembang Student Paper	<1 %
13	Submitted to University of Florida Student Paper	<1 %
14	Nesae Mouzehkesh, Tanveer Zia, Saman Shafigh, Lihong Zheng. "Dynamic backoff scheduling of low data rate applications in wireless body area networks", Wireless Networks, 2015	<1 %

15

Rully Aprilia Zandra. "Daily Score Cards on Android Smartphones", KnE Social Sciences, 2020

Publication

---

<1 %

16

Nattawut Phloymuk, Masaaki Kando, Norasage Pattanadech. "The Investigation of Insulation Performance Evaluation of the Large Electrical Rotating Machine in Frequency Domain", Journal of Mobile Multimedia, 2020

Publication

---

<1 %

17

Submitted to Heriot-Watt University

Student Paper

---

<1 %

18

[cmer.cis.uoguelph.ca](http://cmer.cis.uoguelph.ca)

Internet Source

---

<1 %

19

[docplayer.net](http://docplayer.net)

Internet Source

---

<1 %

20

[journal.uny.ac.id](http://journal.uny.ac.id)

Internet Source

---

<1 %

21

Peter Vankúš. "Influence of Game-Based Learning in Mathematics Education on Students' Affective Domain: A Systematic Review", Mathematics, 2021

Publication

---

<1 %

22

Submitted to University of Bath

Student Paper

<1 %

23

[media.proquest.com](http://media.proquest.com)

Internet Source

<1 %

24

[krishikosh.egranth.ac.in](http://krishikosh.egranth.ac.in)

Internet Source

<1 %

25

[sciencepubco.com](http://sciencepubco.com)

Internet Source

<1 %

26

[www.cambridge.org](http://www.cambridge.org)

Internet Source

<1 %

27

[dokumen.pub](http://dokumen.pub)

Internet Source

<1 %

28

[eprints.uad.ac.id](http://eprints.uad.ac.id)

Internet Source

<1 %

29

[www.science.gov](http://www.science.gov)

Internet Source

<1 %

30

[eprints.uny.ac.id](http://eprints.uny.ac.id)

Internet Source

<1 %

31

[ir.lib.uec.ac.jp](http://ir.lib.uec.ac.jp)

Internet Source

<1 %

32

[ruslanapasri.wordpress.com](http://ruslanapasri.wordpress.com)

Internet Source

<1 %

33

R Sulastri, R Johar, M Duskri, M Ikhsan, H Meutia. "Developing mathematics training

<1 %

modules to enhance teachers' content knowledge", Journal of Physics: Conference Series, 2018

Publication

34

Rodrigo Luis de Souza da Silva, Lohan Rodrigues Narcizo Ferreira, Lidiane Teixeira Pereira. "Immersive Mobile Telepresence Systems: A Systematic Literature Review", Journal of Mobile Multimedia, 2020

Publication

<1 %

35

[docplayer.info](http://docplayer.info)

Internet Source

<1 %

36

Maximilian Dürr, Carla Gröschel, Ulrike Pfeil, Harald Reiterer. "NurseCare: Design and 'In-The-Wild' Evaluation of a Mobile System to Promote the Ergonomic Transfer of Patients", Proceedings of the 2020 CHI Conference on Human Factors in Computing Systems, 2020

Publication

<1 %

37

[article.sapub.org](http://article.sapub.org)

Internet Source

<1 %

38

[www.learntechlib.org](http://www.learntechlib.org)

Internet Source

<1 %

39

[www.maximusproductions.com](http://www.maximusproductions.com)

Internet Source

<1 %

40

Husni Idris, Nurhayati Nurhayati, Satriani Satriani. " Developing Multimedia For

<1 %



# Educational Technology Course of Coastal Area Students ", IOP Conference Series: Earth and Environmental Science, 2018

Publication

---

41

[www.revistacomunicar.com](http://www.revistacomunicar.com)

Internet Source

<1 %

---

42

Akbar Handoko, Santi Sartika, Bambang Sri Anggoro. "Subject-specific pedagogy: Development of biology teaching materials based on van hiele thinking theory", JPBIO (Jurnal Pendidikan Biologi), 2021

Publication

---

<1 %

---

Exclude quotes Off

Exclude matches < 4 words

Exclude bibliography Off